

MODEL U-REPEATER III LIST 2 ISDN 2B1Q REPEATER INSTALLATION/MAINTENANCE

CONTENTS

1. GENERAL	1
2. INSTALLATION	2
3. CIRCUIT TURN UP	3
4. MAINTENANCE	4
5. DEPLOYMENT GUIDELINES	4
6. WARRANTY AND CUSTOMER SERVICE	4

FIGURES

Figure 1. U-Repeater III Circuit Pack	1
Figure 2. Environmental Housing	2
Figure 3. ISDN/DDS Test Access Module	3
Figure 4. Loop Sync Indicators	3
Figure 5. Typical U-Repeater III Circuit Voltage Test Points	5
Figure 6. ISDN U-Repeater III Mixed Gauge Deployment Chart	6

TABLES

Table A. Basic Features	1
Table B. Equipment Options for the U-Repeater III System	2
Table C. LED Indicator Descriptions	3

1. GENERAL

1.1 This practice provides installation and maintenance procedures for the ADTRAN ISDN U-Repeater III. **Figure 1** is a photograph of the circuit pack. The part number and basic features are listed in **Table A**.

1.2 This is the first issue of this practice.

1.3 The ADTRAN U-Repeater III is a device for extending the ISDN Basic Rate Interface (BRI). It is capable of operating up to 42 dB loop loss measured at 40 KHz, with 6 dB ANSI Near End Cross Talk (NEXT) Margin. This allows a maximum DC resistance of 1300 Ω on both the network-side and customer-side loops.

Note: This module is to be used with ADTRAN U-Repeater II Power Module, part number 1212017L1, L2 (T 400) or 1102009L1 (D4) only.

1.4 The ADTRAN U-Repeater III provides a means of extending the digital subscriber loop serving range up to 32 kFt of 26-gauge twisted pair wire/cable utilizing a 2600 Ω total loop resistance design with a centrally located repeater. The unit has no manual option settings

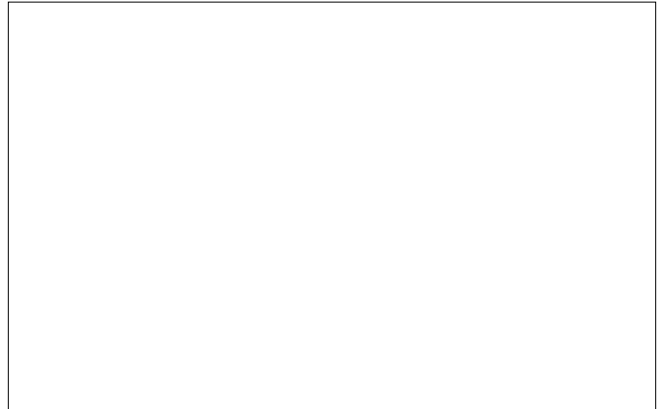

Figure 1. U-Repeater III Circuit Pack

1.5 Power to operate the U-Repeater III is derived from a 43 mA constant sealing current source, independent of line impedance or wire gauge provided by an ADTRAN U-RPM II located in the central office (CO). The repeater uses 36 mA of the current and passes approximately 5 mA to 7 mA to the customer NT1 (sealing current).

Table A. Basic Features

Unit	Part No.	Features
U-Repeater III List 2	1153017L2	<p>Provides an ISDN U-interface toward the network and toward the customer according to ANSI T1.601-1992.</p> <p>Provides both interim path and segmented performance monitoring, per TR-NWT-000397.</p> <p>Provides eight hours of performance monitoring history per TR-NWT-00829.</p> <p>Responds to the eight ISDN BRA National Standard eocmessages</p> <p>Provides lightning and power cross protection required by TR-NWT-001089.</p> <p>Derives operating power from the network-side wire pair, requiring 43 mA constant current at 28 V to the repeater, while supplying 5 mA to 7 mA of sealing current toward the customer.</p> <p>Provides termination signal to NT1 when power is applied and a constant sealing current.</p>

1.6 The U-Repeater III operates at line losses up to 42 dB at 40 kHz, in both directions from the repeater and regenerates the 2B1Q signals to meet the transmitted power spectrum of ANSI T1.601-1992.

1.7 The U-Repeater III is housed in a sealed environmental housing. The type of housing depends upon application requirements. See **subsection 4** for various ADTRAN environmental housings. **Figure 2** is a photograph of an environmental housing. **Table B** provides a list of equipment options used in U-Repeater III applications.

1.8 The U-Repeater III L2 interchanges with the ADTRAN U-Repeater II (1152017L2), but does not interchange with U-Repeater (1150017L1/L2/L3).

Note: Do not remove the metal shell enclosing the circuit pack.

2. INSTALLATION

2.1 The repeater circuit pack is shipped in a separate carton and must be installed in an environmental apparatus case.

2.2 Remove the repeater circuit pack from the carton and visually insure that damage has not occurred during shipping or handling. If damage has occurred, file a claim immediately with the carrier then contact ADTRAN customer service; see **subsection 6.2**.

2.3 **Figure 3** is a photograph of the ADTRAN Test Access Module (ISDN/DDS TAM), Part Number 1152011L1. This module provides test access for testing of the wire pairs and the U-Repeater III at the U-Repeater III housing location.

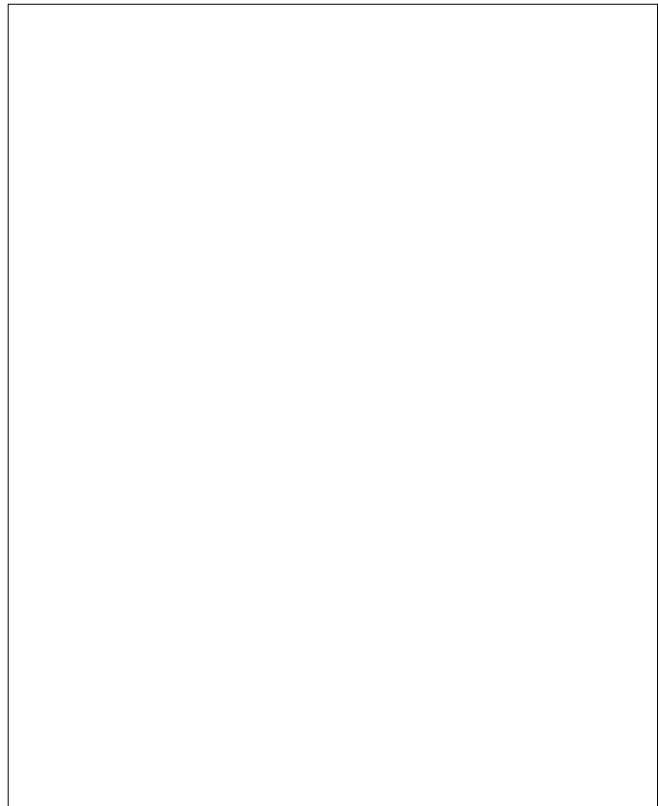

Figure 2. Environmental Housing

Table B. Equipment Options for the U-Repeater III System

Unit	Part Number	CLEI Number	Features
U-Repeater III L2 Circuit Pack	1153017L2	DDRPFG0_ _ _	Dual repeater unit; uses 2B1Q line coding; range up to 16 kFt of 26-gauge wire each direction from repeater; lightning protection; <i>eoc</i> loopback; <i>crc</i> test modes; elastic data buffers for jitter control.
U-Repeater II Powering Module-D4 T400 -48 VDC T400 -72 VDC	1102009L1 1212017L1 1212017L2	DDRPGH6_ _ _ DDRPHH6_ _ _ DDRPHB6_ _ _	Provides constant 43 mA down signal pair to power one repeater, allows for passive customer data flow, monitors the line for excessive resistance or open loop, standard D4 or T400 size plug-in.
U-Repeater Powering Shelf (GPC L3)	1150001L3	D4MEE30_ _ _	Single height shelf accommodates up to 12 D4 U-RPM IIs, fused -48 V alarm output, connectorized input/output.
T400-19 Shelf	1150028L1	NDMMAA0_ _ _	19" Rackmount shelf houses up to 12 U-RPM T400 circuit packs.
NT1 T400-23 Shelf, Rackmount	1150024L1	NDMMBA0_ _ _	23" Rackmount shelf houses up to 12 U-RPM T400 circuit packs.
NT1 T400-23 Enclosed Wallmount Shelf	1150024L2	N/A	23" Wallmount shelf houses up to 12 U-RPM T400 circuit packs.



Figure 3. ISDN/DDS Test Access Module

2.4 **Figure 3** is a photograph of the ADTRAN Test Access Module (ISDN/DDS TAM), Part Number 1152011L1. This module provides test access for testing of the wire pairs and the U-Repeater III at the U-Repeater III housing location.

Four Bantam jacks make the pairs available for metallic test and transmission impairment measurements. Two RJ-48 jacks enable bit error rate and functional testing of the CO pairs and the U-Repeater III by using an ISDN test set.

Optioning the U-Repeater III

2.5 The repeater circuit pack has no option settings.

CAUTION

The apparatus case must be considered to be under pressure, and should be handled accordingly.

2.6 Select a suitable site or pole along the main cable where a loop loss up to 42 dB at 40 kHz is measured from the U-LT to the repeater.

The loop loss from the repeater to the customer site should not exceed 42 dB at 40 kHz, unless a bit error rate (BER) measurement is performed to ensure a maximum BER of less than 1×10^{-7} .

Note: Only one repeater may be used in an ISDN Basic Rate local loop.

3. CIRCUIT TURN UP

3.1 A green LED at the rear of the unit is provided to aid in circuit turn up and diagnostics; see **Figure 4**. The indications provided by this LED are described in **Table C**.

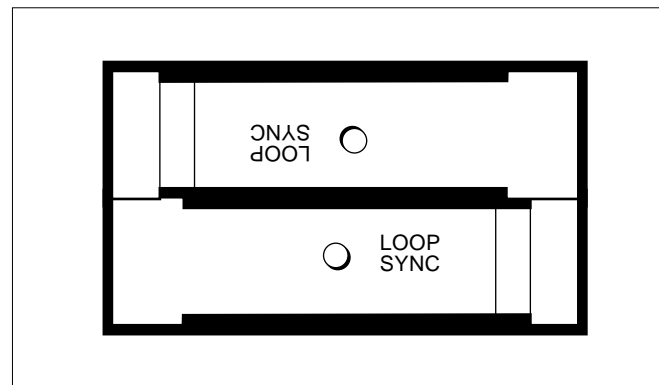

Figure 4. Loop Sync Indicators

INDICATION	MEANING
LED <i>Flashes</i> three times after inserting unit into slot.	Unit receiving power, self test passed.
LED <i>Flashes</i> once per second.	U-Interface synchronized to network.
LED <i>On</i> solid.	U-Interface synchronized on network and customer sides.

Table C. LED Indicator Descriptions

3.2 Upon insertion into the correct slot in an environmental housing, the LOOP SYNC indicator at the rear of the unit away from the edge connector (see **Figure 4**) *Flashes* green three times. This indicates that the unit is receiving power from the U-RPM and has passed a power-on self test. Failure of this indication may be due to incorrect or shorted wiring, either at the MDF between the LT and the U-RPM or between the U-RPM and the U-Repeater III, or may be due to insertion in an incorrect slot of the environmental housing. These conditions must be cleared before circuit turn up may proceed.

3.3 After verifying that the unit is receiving power from the U-RPM, the next step is to verify loop synchronization between the LT and the U-Repeater III. Once the network side of the unit has achieved synchronization to the LT the LOOP SYNC *Flashes* once per second. Failure of the unit to synchronize to the LT may be caused by a bad or incorrect line card, loop loss in excess of 42 dB @ 40 kHz, or excessive noise on the loop. These conditions must be cleared before proceeding.

3.4 After the unit has achieved synchronization to the network, synchronization to the customer may be verified if the customer NT1 is installed. Once the U-Repeater III synchronizes to the customer NT1 the LOOP SYNC remains *On*. This indicates that a Layer 1 connection between the LT and the customer NT1 has been established. Failure of the unit to synchronize to a properly installed NT1 may indicate excessive loop loss or noise, or faulty wiring.

4. MAINTENANCE

4.1 The U-Repeater III requires no routine maintenance to operate. In case of equipment malfunction, advise the CO to perform an *mp-eoc* loopback test, per TR-NWT-000397. If a malfunction is confirmed replace the U-Repeater III circuit pack; see **subsection 4.3**.

4.2 The Repeater has looping (B1, B2, and 2B+D) capability through the maintenance channel which allows for digital loopback, per T1.601-1992, to aid in fault isolations. The looping is accomplished remotely from the CO switch or from the ADTRAN U-BR1TE channel unit location. In addition, eight hours of performance history is available to the network as described in TR-NWT-000829. This performance history may be used for troubleshooting and fault isolation purposes.

Replacement of Circuit Packs

4.3 When testing indicates a faulty circuit pack, refer to the practice for the housing being used for entry and pressurization control.

4.4 Replace the faulty circuit pack.

4.5 Advise the CO to perform an *mp-eoc* loopback test, per TR-NWT-000397.

4.6 ADTRAN recommends that no repairs to the circuit pack be performed in the field. Repair services may be obtained by returning a defective unit to the ADTRAN Repair Department.

Testing the Repeater at the Central Office

4.7 The U-Repeater III performs the standard *mp-eoc* loopbacks described in TR-NWT-000397.

Typical Voltage Measurements (Normal Operation Condition)

4.8 **Figure 5** depicts a typical loop originating at the LT U-Interface and terminating at the customer NT1. Use a digital multimeter to measure across the loop as demonstrated in the illustration.

The test points (A, B, and C) should contain the following voltage readings under normal operating conditions.

A. 28 VDC to 120 VDC. Actual voltage equals 28V plus the line voltage drop between the U-RPM and the U-Repeater III.

B. 28 VDC + -3 V

C. 1. Not terminated at NT1 = 28 V ± 3 V
2. Terminated at NT1 = 6 to 12 V

5. DEPLOYMENT GUIDELINES

5.1 See **Figure 6** for information regarding deployment guidelines for ISDN 2B1Q loop transmission.

6. WARRANTY AND CUSTOMER SERVICE

ADTRAN will replace or repair this product within five years from the date of shipment, if the product does not meet its published specifications or if it fails while in service. For detailed warranty, repair, and return information, refer to the ADTRAN Equipment Warranty and Repair and Return Policy Procedure.

6.1 Return Material Authorization (RMA) is required prior to returning equipment to ADTRAN.

6.2 For service, RMA requests, or further information, contact one of the following numbers.

ADTRAN Customer Service:

RMA	(205) 971-8722
Technical Support	(800) 726-8663
Applications Engineering	(800) 615-1176
Sales	(800) 827-0807

Repair and Return Address:

ADTRAN, Inc.
Customer Service Department
901 Explorer Boulevard
Huntsville, Alabama 35806-2807

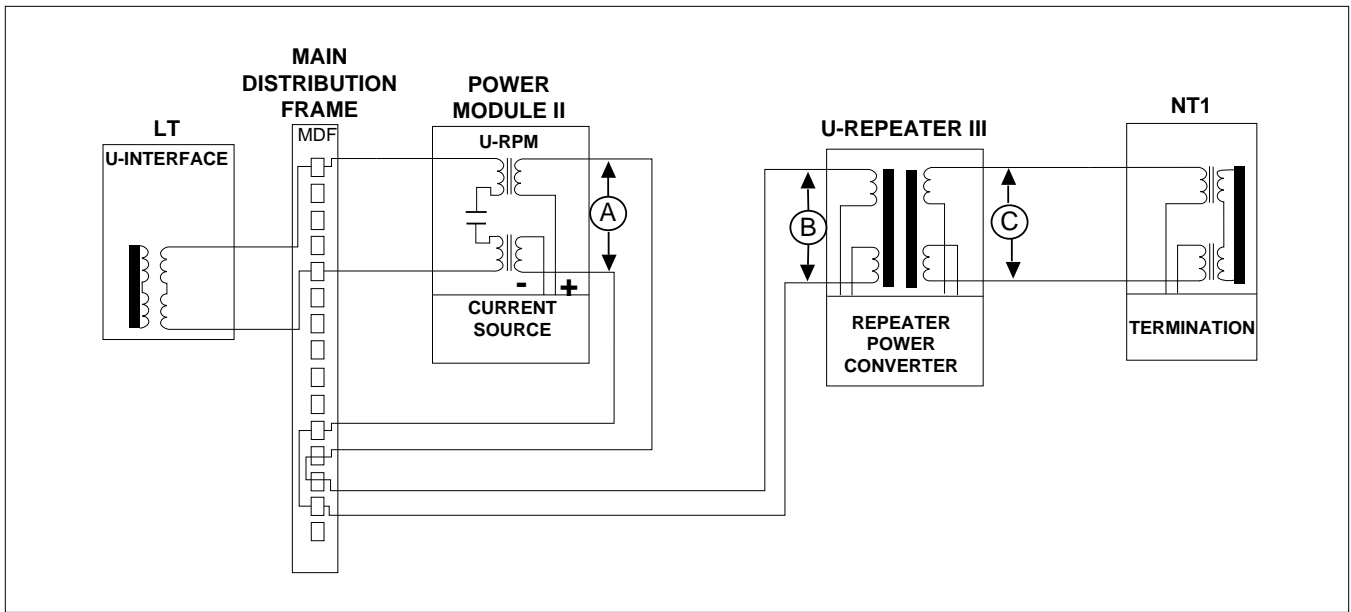
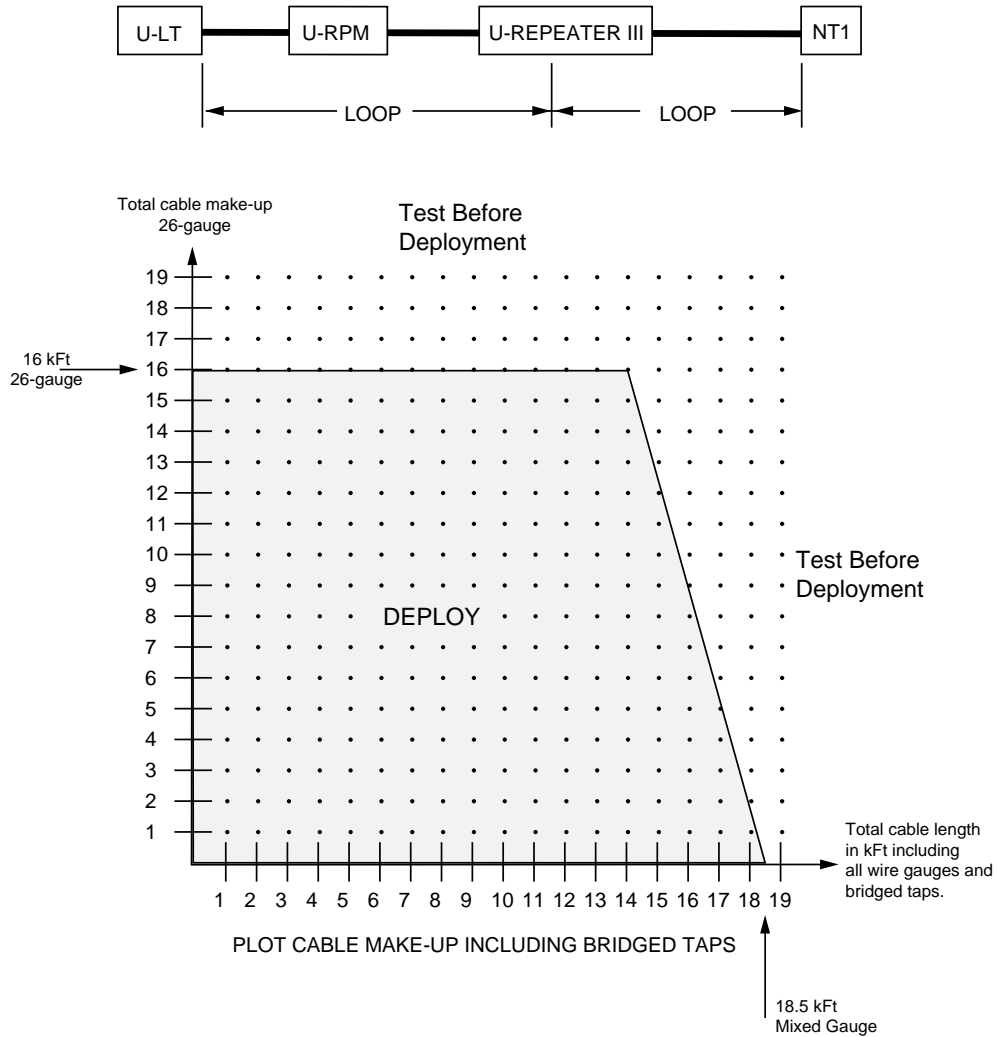

Figure 5. Typical U-Repeater III Circuit Voltage Test Points



How to use this guideline:

1. Calculate the total length of 26-gauge wire, then plot on vertical axis.
2. Calculate the total length of wire in the cable make-up including 26-gauge and all bridged taps. Plot this total length on the horizontal axis.

If the plotted point falls within the solid line boundaries, the U-Repeater III can generally be deployed without testing.

If the plotted point is outside the solid line boundary, long term performance of the U-Repeater III can not be guaranteed. If deployment is desired, the circuit must be measured for all line qualification requirements and must be tested for performance. If these requirements are not met or performance does not pass, the circuit must be reengineered.

Line Qualification Requirements	
Maximum single bridged tap:	1.5 kFt (0.45 km)
Maximum total bridged tap:	4.5 kFt (1.37 km)
Maximum bridged taps:	3
Maximum resistance: (each side)	1300 Ω
Maximum loss at 40 KHz:	42 dB
Maximum Noise: (135 Ω termination, 50 kB filter)	-57 dBm
Maximum impulse noise threshold: (135 Ω input, 50 kB filter, seven or less counts in 15 minutes)	-40 dBm

Figure 6. ISDN U-Repeater III (Third Generation) Mixed Gauge Deployment Chart